



HiFlux Filtration A/S

Professional SELF-CLEANING Liquid filter solutions

Auto-line© Self-cleaning filters VLR-E



Auto-line© Automatic Filters - VLR-E

HiFlux Auto-line filters are designed as compact self-cleaning automatic filters with a wide range of applications for various types of liquids. The sturdy construction of the filter makes it well suited for industrial and hygienic applications in which operational reliability and dependability are essential.

The industrial Auto-line filter is used in many sectors such as paint, cooling water, waste water, technical water, heat exchanger, chemicals, resins and the energy sector.

The Auto-line filter is used when an automatic continuous cleaning process is required. The impurities are being concentrated in the filter, until it is drained away, while the filter is still in operation the liquid loss due to cleaning is minimal.

In the design of the filter it was very important to make the construction robust and reliable. By limiting the number of moving components, wear and maintenance requirements are minimized. The simple construction makes the filter very easy to service, since there is no need for external service assistance or special tools.

Special versions can be supplied according to customer requirements. Typically different connections, temperature and pressure levels.

CE ISO 9001 EHEDG

Capacity: 448 - 970 m³/h

Filtration: 100 - 1000 µm

Pressure: 10 bar

- **Removes unwanted particles**
High operational reliability
- **Continuous flow process**
Self-cleaning application
- **Ensures the quality**
Increased product safety
- **Eliminates downtime**
Optimizing earnings
- **Savings on running costs**
Purchase and exchanging filter bags is no longer needed



VLR-E

Auto-line© Automatic Filters - VLR-E

Product specifications

HiFlux Auto-line filters are manufactured of stainless acid-resistant steel. The filter meets current standards and norms for pressure vessels, complies with the Machinery directive. The filter is CE labelled when the filter complies with relevant legislation.

The filter can be delivered ready for installation, complete with electronic controller and automatic drainvalve.

The Auto-line filter solutions has a wide range of addons, such as: lifting device, sealings, inverter, pressure sensors, de-air valve, legs and much more.

Filter vessel and element:	EN 1.4404 steel
Design pressure:	10 bar
Test pressure:	According to EN 13445
Max differential pressure:	3-7 bar
Max working temperature:	80°C (Fluid grp. 2 and vapor pre. < 0,5 bar)
Volume:	485,0 liters
Weight:	650 kg
Power supply:	3 x 230/400V, 50 Hz
Air supply:	6 bar, filtered
Flange connection:	DN350 PN16 EN1092-1/11
Drain:	Nipple Rp2 or DN50 PN16 EN1092-1/11
Drain chamber volume:	22,0 liters
Filtration:	100-200-300-500-1000 µm

Customized solutions can be manufactured upon request.

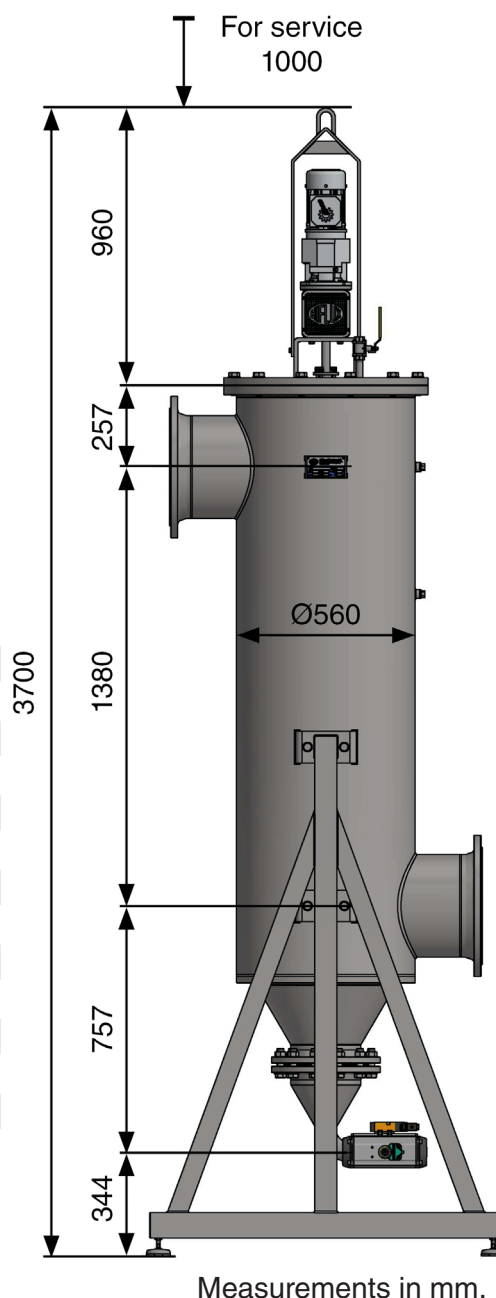

Capacity (at a viscosity of 1 cSt and as a pressure filter)

Diff. pressure (bar)	Strainer area cm ²	100 µm	150 µm	200 µm	300 µm	500 µm	1000 µm
0,05	14.400	448	448	448	490	490	490
0,10	14.400	642	642	642	690	690	690
0,15	14.400	792	792	792	840	840	840
0,20	14.400	918	918	918	970	970	970

Capacity (m³/ h) at different filtration rates (µm).

The filter should only be installed as a pressure filter in systems which have a positive overpressure (the surroundings must be taken into consideration). All Auto-line filters are standardly produced according to the pressure equipment directive 2014/68/EU article 4, section 3. The filters can be delivered with approval according to category I, II, III or IV.

The Auto-line filters complies with the Machinery directive 2006/42/EC. Auto-line filters can be delivered with approval for use in explosive atmospheres (Equipment-category 2, zone 1) according to directive 2014/34/EU.